

15 LF

132 - 151 kNm	8 - 10,4 m	3,5 - 3,9 m	3,8 - 5 m	2.205 - 2.490 kg	415°	25 kNm	260 - 300 bar	1x Minimum 80 l/min ~ 40 kW	2x Minimum 65 l/min ~ 66 kW	LS Minimum 170 l/min ~ 85 kW

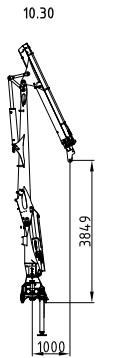

Socket schmal
Crane base small

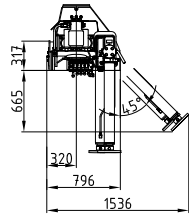
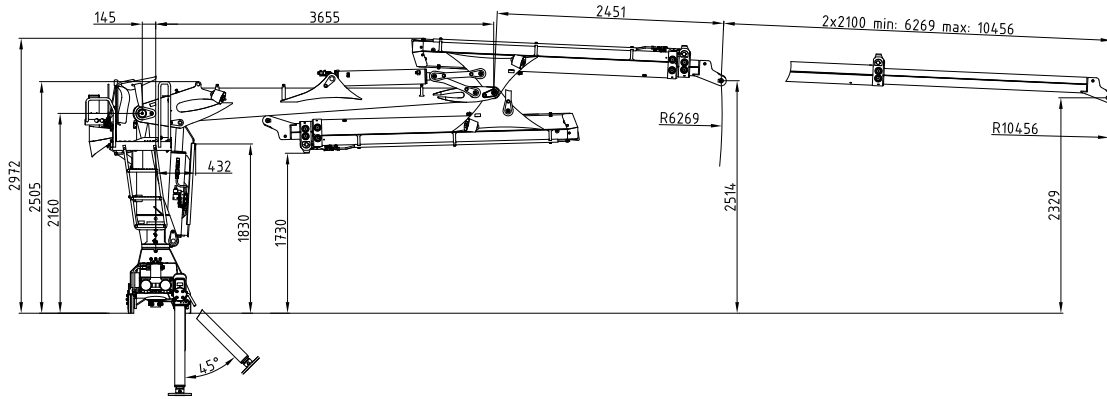
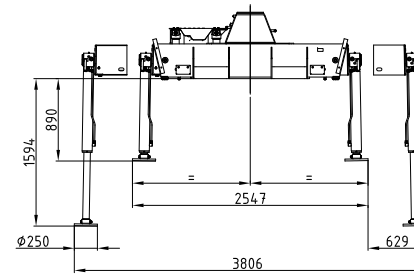

Socket breit
Crane base wide

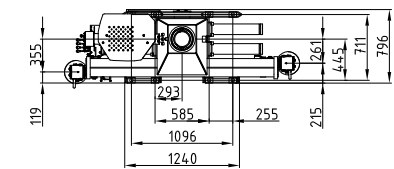
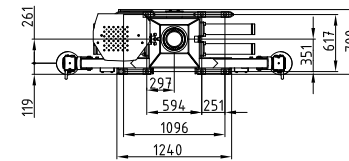
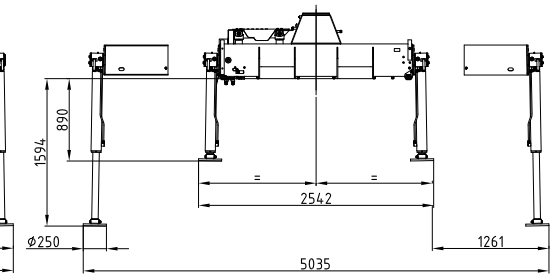

Rücksitz 01
Back seat 01

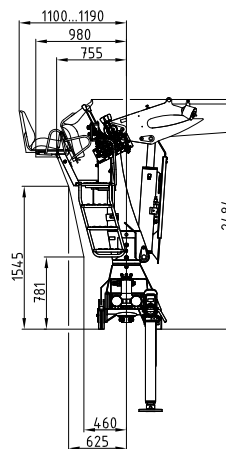

Rücksitz 04
Back seat 04

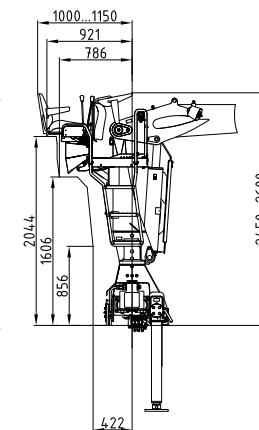

Seitensitz 04
Side seat 04

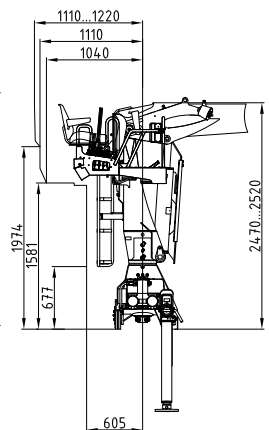

170° Hochklappung
170° of lifting up

